

A powerful line boring machine that can be customized to suit your needs

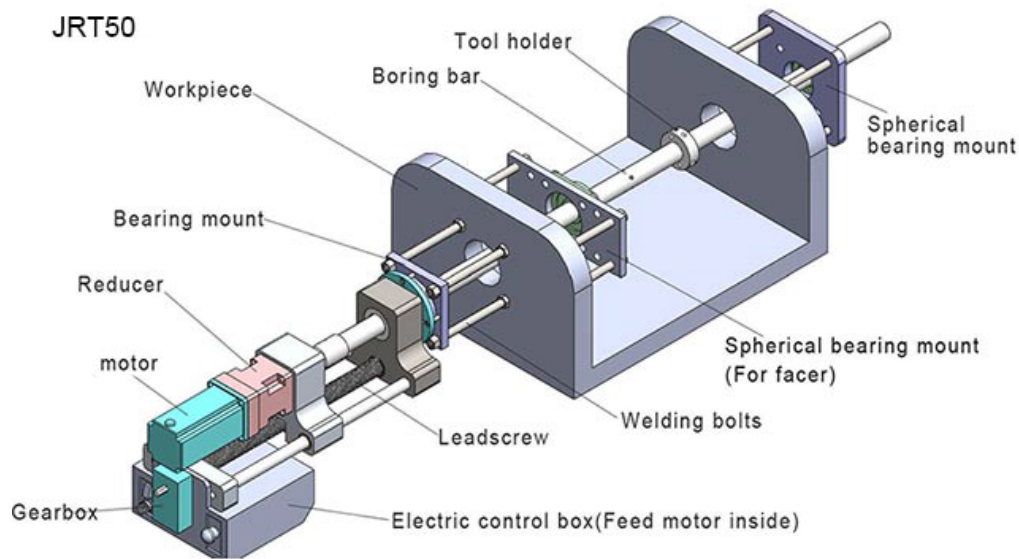

JRT50 Portable Line Boring Machine is a compact, versatile and powerful line boring machine. It can be adapted to variety of the tight space. It is widely used for excavator, loader, bulldozer, crane buckets repair.

- Modular components make setup quick and easy
- Two electric motors make the machine easy to control
- Flexible and high quality design, aluminum alloy frame make the machine portable
- Optional facer tool make the machine versatile
- Spherical bearing mounts system allow quick setup
- Gear box allow manual and automatic feed
- Powered by a DC motor, powerful and stable



Technical Details

Boring Bar Diameter	50mm (1.97 inches)
Length of standard boring bar	1500mm (59.06 inches) (Customizable)
Boring Diameter	55-250mm (2.17-9.84 inches)
Power unit	Dc motor 1.5Kw
Roating speed	0-100rpm(variable speed change)
Boring stroke	390mm (15.35 inches)
Axial feed speed	0-100mm/min(variable speed change)
Facing Diameter	60-260mm (1.97-10.27 inches)

Standard Accessories and Components

Drive unit (Main body of the machine)	1 Set
Boring bar (50*1500mm) (1.97*59 Inches)	1 Pc
Bearing mounts (bearing contained)	2 Sets
Bolts for welding (nuts contained)	8 Pcs
Centering Cones	2 Pcs
Tool holder	3 Pcs
Cutter tools	2 Pcs
Wrench tool	1 Set
Operating manual	1 Pc

Optional Facer and Facing Rang

50D Facer	
Boring Bar	50mm (1.97 inches)
Facing Diameter	60-260mm (2.36-10.27 inches)
Swing Diameter	264mm (10.39 inches)
Feeding rate per revolution	0.125mm (0.0049 inches)

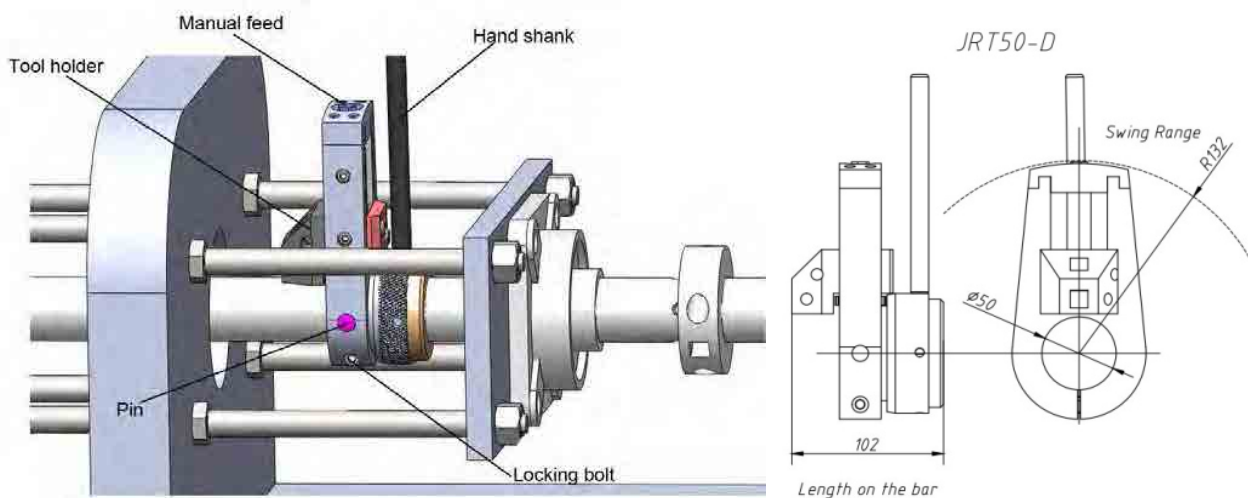

How to set up and use the facer

The Facer attaches directly to the boring machine and assembly clamps securely to any location along the boring bar for quick and easy setup. It will greatly extend the versatility of your JRT50 portable line boring machine.

With Model YT70 hydraulic bushing tool to disassemble excavator bushings, axles and bearings is easy and saves time. There are hand pump and 220v/380v electric pump for you.

The traditional way of working using a slide-hammer or other lumbering tools can easily damage vehicle parts. This is in most cases avoided by using Model YT70 hydraulic bushing tool kit.

SPECIFICATIONS

Technical Details		
	Hand Pump	
1	Maximum hand force of manual reversing pump	50Kg
2	Working pressure	high pressure 0-63mpa, low pressure 4Mpa
3	Working flow	high pressure flow 7ml/ time low pressure flow 50ml/ time
4	Tank capacity (L)	13L
5	Oil	46# hydraulic oil
	Electric pump	
6	Motor power	1.5kw 220V or 380V
7	Working pressure	0-63mpa
8	Working flow	1.2l /min
9	Tank capacity (L)	16L
10	Oil	46# hydraulic oil
	Hydraulic Cylinder	
11	Hydraulic cylinder thrust	70T
12	Stroke	100mm
13	Pressure sleeve range	60-120mm
14	cylinder aperture	50mm



Hand Pump

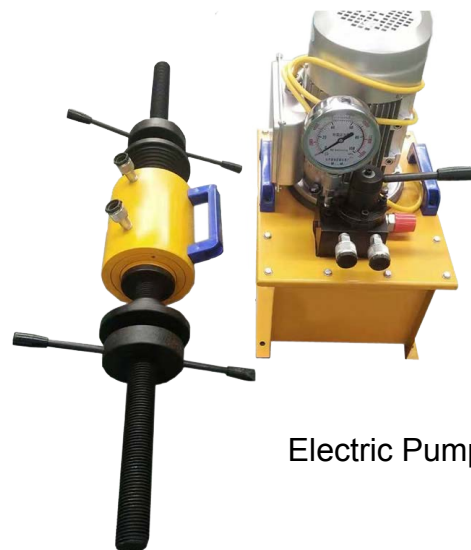

Electric Pump

